



MAGNETIC FLOW METER M-2000 SERIES



6

FLOW

DESCRIPTION

The **Badger Meter M-2000 Series magnetic flow meter** is the result of years of research and field use in electromagnetic flow meters. The M-2000 can measure almost any liquid, slurry or paste that has minimum electrical conductivity. These meters are perfect for flow measurement in commercial HVAC water systems, wastewater, reclaimed water, irrigation and industrial applications because they can handle suspended solids, have no pressure drop, no moving parts, and their accuracy is not affected by temperature, pressure, viscosity, density or flow profile. They are NSF listed for use in potable water. The ANSI 150 RF flanged pipe spool makes them easy to install and they are available with the NEMA 4X (IP66) integral amplifier (transmitter and display housing) mounted atop the flow detector housing, or with the amplifier remotely mounted. For the remote mount configuration, a 30 ft. cable is standard (other lengths available) and the detector housing comes with either a NEMA 4X or NEMA 6P (submersible) junction box. Each meter is factory calibrated and tested and a certificate is included.



FEATURES

- **High accuracy of +/- 0.25% and flow range of 300:1 for reliable measurement**
- **Unaffected by most solids contained in the fluid for application flexibility**
- **Pulsed DC magnetic field for zero point stability**
- **Corrosion resistant liners provide long life**
- **Grounding rings included for non-conductive piping**
- **Bidirectional flow sensing and totalization for reversing system application**
- **Empty pipe detection feature generates error message when pipe is not full**
- **NEMA 4X (IP66) enclosure for installation in exposed areas**
- **Large backlit 4-line, 20 character LCD display for local indication and programming even in low light conditions**
- **Modbus RTU via RS232 communications for network systems**

SPECIFICATIONS	
Supply Voltage 85-265 VAC (45-65 Hz) Supply Watts 15 W Digital Inputs Maximum 30 VDC, programmable as positive zero return, external totalizer reset, or preset batch start	Engineering Units Ounces, pounds, liters, US gallons, imperial gallons, barrels, hectoliters, megagalions, cubic meters, cubic feet, acre feet Pipe Size Range 1" to 24" standard (1/4", 1/2" and 28" to 54" also available), ANSI 150 RF flanges standard Flow Range Unidirectional or bidirectional with two separate totalizers (programmable) Velocity Range 0.10 to 39.4 fps (0.03 to 12 mps) Operating Temperature -4° to 140°F (-20° to 60°C) Operating Humidity Up to 90% non-condensing Media Compatibility Many fluid applications including hot or chilled water, glycol solutions; minimum conductivity 5.0 μΩ/cm Media Temperature Range 178°F (80°C) with rubber liner; 212°F (100°C) with PTFE liner and local mount amp; 311°F (155°C) with PTFE liner and remote mount amp Maximum Pressure 285 psig at ambient temperature, refer to ANSI B16.5 standard for 150 lb RF flanges for temperature/pressure spec Materials Of Construction Meter housing and flanges: carbon steel Liner: Rubber Electrodes: Alloy C Pipe spool: 316 SS Grounding rings: stainless steel Amplifier housing: cast aluminum with powder-coat paint NEMA 4X (IP66) amplifier housing; NEMA 4X or NEMA 6P detector housing junction box for remote mount configuration Enclosure Rating NSF Listed, CE Approvals NSF Listed, CE Warranty 1 year
Maximum Output Impedance 800 ohms @ 24 VDC Outputs 0-20 mA, 4-20 mA, 0-10 mA, or 2-10 mA Analog output Four configurable, 24 VDC sourcing outputs (maximum of two) 50 mA each or 100 mA total, sinking open collector outputs (maximum of four) 100 mA each or 30 VDC total, AC solid state relay (maximum of two) 48 VAC Digital outputs 500 mA maximum Pulse outputs Scalable up to 10 kHz, passive open collector up to 10 kHz active switched 24 VDC, up to two outputs (forward and reverse flow), pulse width programmable from 1 to 1,000 ms or 50% duty cycle Frequency output Scaleable up to 10 kHz open collector, up to 1 kHz solid state relay Alarm High/low flow alarm, error alarm, empty pipe alarm outputs Wiring Terminations 1/2" NPT conduit connection and 3 cord grips on amplifier housing; 30 ft. standard length cable for remote mount configurations (other lengths available) Communication RS232 - Modbus RTU or remote display Accuracy ±0.25% of flow rate for velocities greater than 1.64 fps (0.5 mps); ±0.004% for lower velocities Repeatability ±0.1% Display Backlit, 4 line, 20 character LCD and 3-button programming keys	

WIRING

DIGITAL INPUT

PROGRAMMABLE FUNCTIONS
 REMOTE RESET
 BATCH RESET
 POSITIVE RETURN TO ZERO

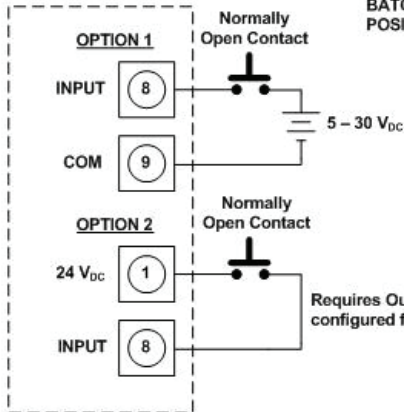

ANALOG OUTPUT

PROGRAMMABLE RANGE
 4-20 mA
 0-20 mA
 2-10 mA
 0-10 mA

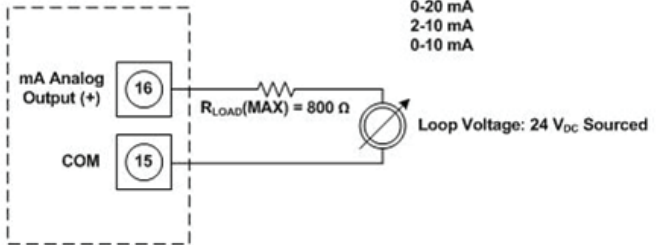

OUTPUT #1

PROGRAMMABLE FUNCTIONS
 FORWARD PULSE
 REVERSE PULSE
 AMR PULSE
 FLOW SET POINT
 EMPTY PIPE ALARM
 FLOW DIRECTION
 PRESET OUTPUT
 ERROR ALARM
 24VDC SUPPLY

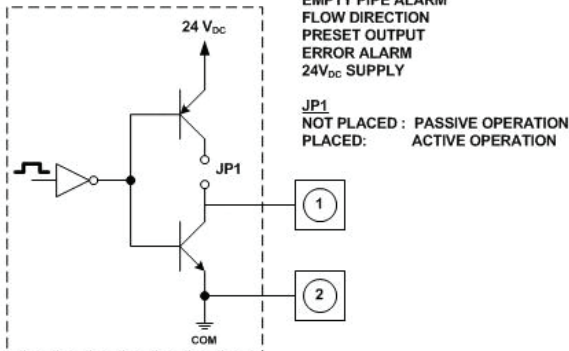

OUTPUT #2

PROGRAMMABLE FUNCTIONS
 FORWARD PULSE
 REVERSE PULSE
 FLOW SET POINT
 EMPTY PIPE ALARM
 FLOW DIRECTION
 PRESET OUTPUT
 ERROR ALARM
 24VDC SUPPLY

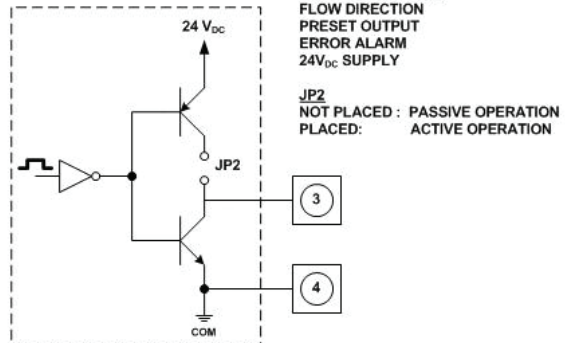

OUTPUT #3

PROGRAMMABLE FUNCTIONS
 FREQUENCY OUTPUT
 FLOW SET POINT
 EMPTY PIPE ALARM
 FLOW DIRECTION
 PRESET OUTPUT
 ERROR ALARM

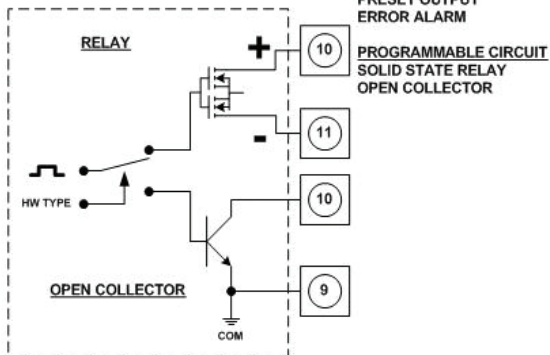

OUTPUT #4

PROGRAMMABLE FUNCTIONS
 FLOW SET POINT
 EMPTY PIPE ALARM
 FLOW DIRECTION
 PRESET OUTPUT
 ERROR ALARM

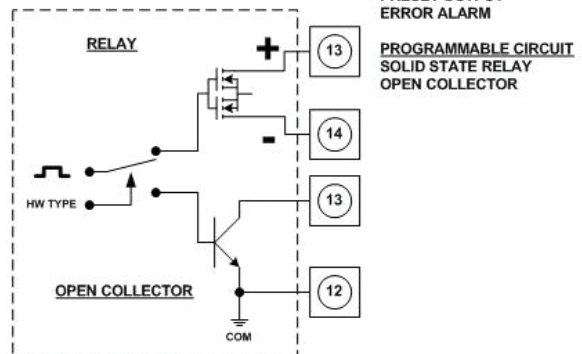



DIMENSIONS

Note: Dimension D in table below is overall height (similar to dimension B) to the top of junction box, for assemblies with remote amplifier configuration.

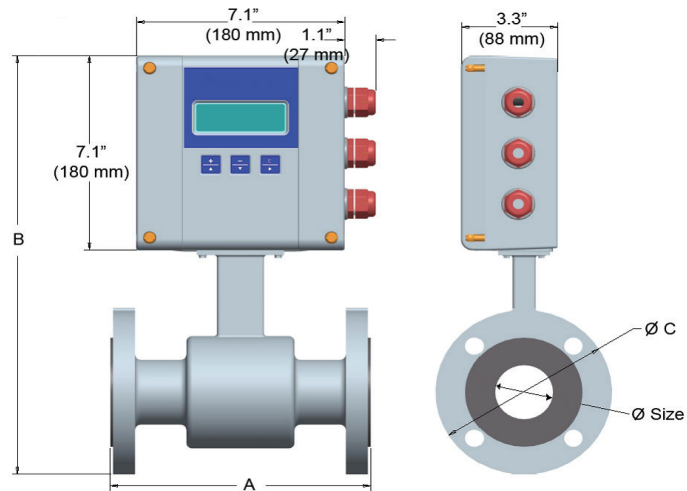

DIMENSIONS AND FLOW RANGES

Size	A	B	C	D	Weight	Flow Range
1" (DN25)	8.9" (22.5 cm)	14.4" (36.6 cm)	4.3" (10.8 cm)	11.7" (29.8 cm)	18 lb (8.0 kg)	0.3 to 93 gpm (1.2 to 350 lpm)
1-1/4" (DN32)	8.9" (22.5 cm)	15.2" (38.6 cm)	4.6" (11.7 cm)	12.5" (31.8 cm)	20 lb (9.0 kg)	0.5 to 150 gpm (2.0 to 575 lpm)
1-1/2" (DN40)	8.9" (22.5 cm)	15.4" (39.0 cm)	5.0" (12.7 cm)	12.7" (32.2 cm)	21 lb (9.5 kg)	0.8 to 239 gpm (3 to 900 lpm)
2" (DN50)	8.9" (22.5 cm)	15.9" (40.3 cm)	6.0" (15.2 cm)	13.2" (33.5 cm)	26 lb (11.5 kg)	1 to 373 gpm (4.7 to 1400 lpm)
2-1/2" (DN65)	11.0" (28.0 cm)	17.1" (43.4 cm)	7.0" (17.8 cm)	14.4" (36.6 cm)	52 lb (23.5 kg)	2 to 631 gpm (8 to 2400 lpm)
3" (DN80)	11.0" (28.0 cm)	17.3" (44.0 cm)	7.5" (19.1 cm)	14.7" (37.2 cm)	54 lb (24.5 kg)	3 to 956 gpm (12 to 3600 lpm)
4" (DN100)	11.0" (28.0 cm)	18.4" (46.6 cm)	9.0" (22.9 cm)	15.7" (39.8 cm)	56 lb (25.5 kg)	5 to 1493 gpm (19 to 5600 lpm)
5" (DN125)	15.8" (40.0 cm)	19.6" (49.8 cm)	10.0" (25.4 cm)	16.9" (43.0 cm)	58 lb (26.0 kg)	8 to 2334 gpm (30 to 8800 lpm)
6" (DN150)	15.8" (40.0 cm)	20.6" (52.4 cm)	11.0" (27.9 cm)	17.9" (45.6 cm)	60 lb (27.0 kg)	11 to 3361 gpm (40 to 12,700 lpm)
8" (DN200)	15.8" (40.0 cm)	22.5" (57.2 cm)	13.5" (34.3 cm)	20.4" (51.8 cm)	86 lb (39.0 kg)	20 to 5975 gpm (75 to 22,600 lpm)
10" (DN250)	19.7" (50.0 cm)	26.8" (68.1 cm)	16.0" (40.6 cm)	24.1" (61.3 cm)	178 lb (81 kg)	30 to 9336 gpm (120 to 35,300 lpm)
12" (DN300)	19.7" (50.0 cm)	28.9" (73.4 cm)	19.0" (48.3 cm)	26.2" (66.6 cm)	207 lb (94 kg)	45 to 13,444 gpm (170 to 50,800 lpm)
14" (DN350)	19.7" (50.0 cm)	30.8" (78.2 cm)	21.0" (53.3 cm)	28.2" (71.6 cm)	258 lb (117 kg)	60 to 18,299 gpm (230 to 69,200 lpm)
16" (DN400)	23.6" (59.0 cm)	33.7" (85.6 cm)	23.5" (59.7 cm)	31.0" (78.8 cm)	306 lb (139 kg)	80 to 23,901 gpm (300 to 90,400 lpm)
18" (DN450)	23.6" (59.0 cm)	35.0" (89.0 cm)	25.0" (63.5 cm)	32.4" (82.2 cm)	400 lb (181 kg)	100 to 30,250 gpm (380 to 114,000 lpm)
20" (DN500)	23.6" (59.0 cm)	38.2" (96.9 cm)	27.5" (69.9 cm)	35.5" (90.1 cm)	493 lb (224 kg)	125 to 37,346 gpm (470 to 140,000 lpm)
22" (DN550)	23.6" (59.0 cm)	39.6" (100 cm)	29.5" (74.9 cm)	36.9" (93.7 cm)	523 lb (237 kg)	150 to 45,188 gpm (570 to 170,000 lpm)
24" (DN600)	23.6" (59.0 cm)	42.2" (107 cm)	32.0" (81.3 cm)	39.5" (100 cm)	552 lb (251 kg)	180 to 53,778 gpm (680 to 200,000 lpm)



MAGNETIC FLOWMETER M-2000 SERIES

APPLICATION AND INSTALLATION

The **M-2000** provides two amplifier mounting options, integral or remote. The amplifier housing is NEMA 4X rated and can be located outdoors; observe the operating temperature range of -4° to 140°F (-20° to 60°C). If located outdoors, provide a roof or shield over the amplifier to protect the LCD display from direct sunlight. If the amplifier is to be remote mounted, standard available cable lengths are 15', 30', 50' and 100' (up to 500' optional).

Magnetic flowmeters can operate accurately in any pipeline orientation and can measure flow in both directions. A "Forward Flow" direction arrow is printed on the detector label. They also perform best when placed in a vertical pipe with the liquid flowing upward; this assures a full pipe at all times and minimizes sediment deposits on the liner and electrodes. If mounting in a horizontal pipe, mount the detector such that the electrodes are on the sides of the pipe, not the top and bottom, also to minimize deposits and build-up on the electrodes. Avoid locations where a partially-filled piping situation can occur; the meter will display an "Empty Pipe Detection" message and will stop measuring flow until the pipe is full.

6

Sufficient straight-pipe runs are required for optimum accuracy and performance. A minimum of 3 diameters upstream and 2 diameters downstream are required (more is better).

Grounding is critical for magnetic flow meters; they must be electrically connected to the liquid media. If using non-conductive piping, the grounding rings (included) must be properly installed. See the M-2000 manual for details.

ORDERING INFORMATION

MODEL	DESCRIPTION
M2K-	Magnetic flowmeter
	SIZE CODE PIPE SIZE
	010 1"
	013 1-1/4"
	015 1-1/2"
	020 2"
	025 2-1/2"
	030 3"
	040 4"
	050 5"
	060 6"
	080 8"
	100 10"
	120 12"
	140 14"
	160 16"
	180 18"
	200 20"
	220 22"
	240 24"
	LINER CODE LINER MATERIAL
	R- Rubber
	T- PTFE
	AMPLIFIER OPTIONS
	LC Local mount amplifier, NEMA 4X (IP66) housing
	RM-N4X Remote mount amp, 30 ft. cable, NEMA 4X junction box on detector tube
	RM-N6P Remote mount amp, 30 ft. cable, NEMA 6P junction box on detector tube

M2K-

040

R-

LC

Example: M2K-040R-LC 4" magnetic flowmeter with rubber liner, local mount amplifier